

ZO1 SYSTEM BLOCK DIAGRAM

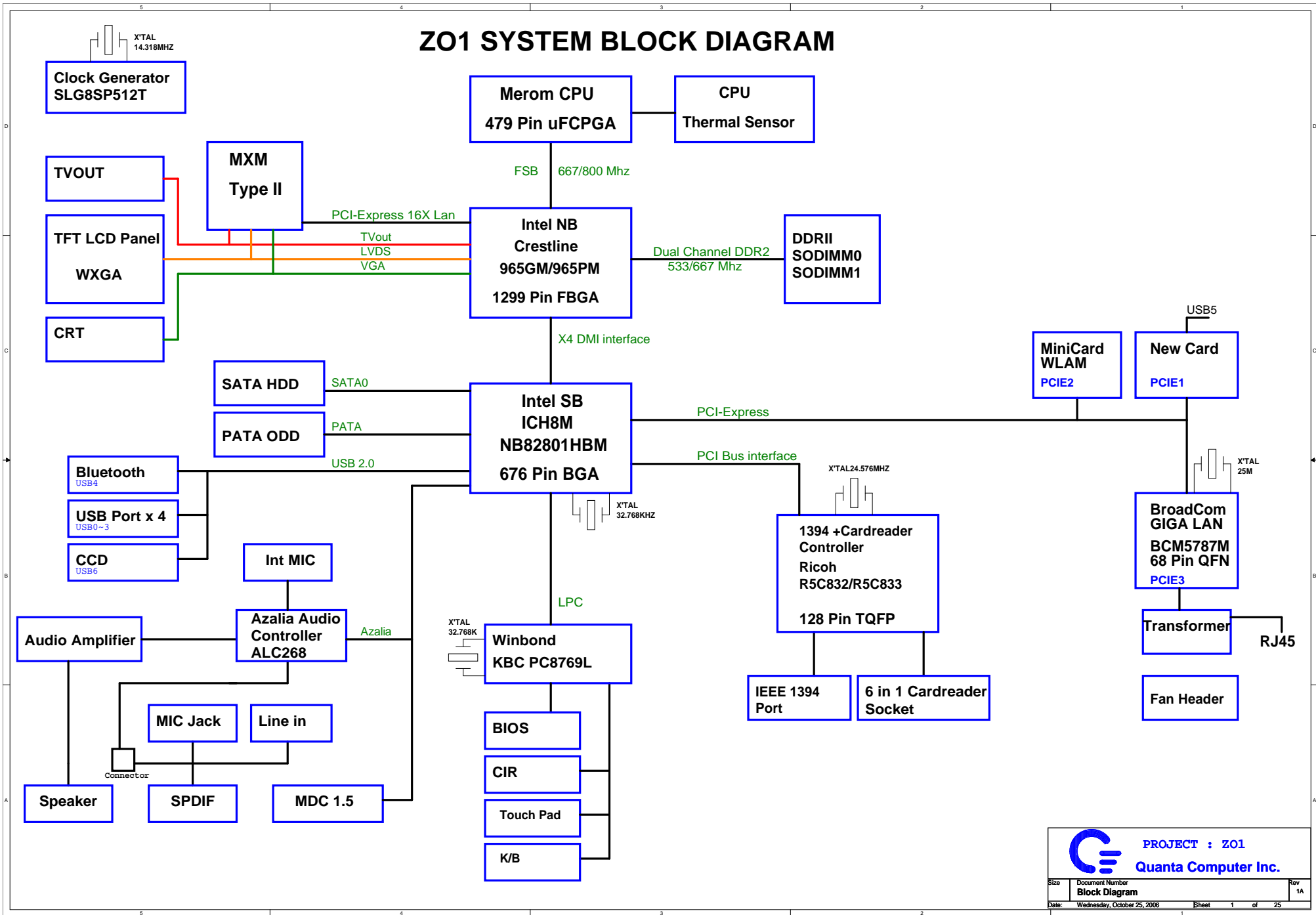

PROJECT : ZO1
Quanta Computer Inc.

Size	Document Number	Rev
	Block Diagram	1A
Date:	Wednesday, October 25, 2006	Sheet 1 of 25

Clock Generator

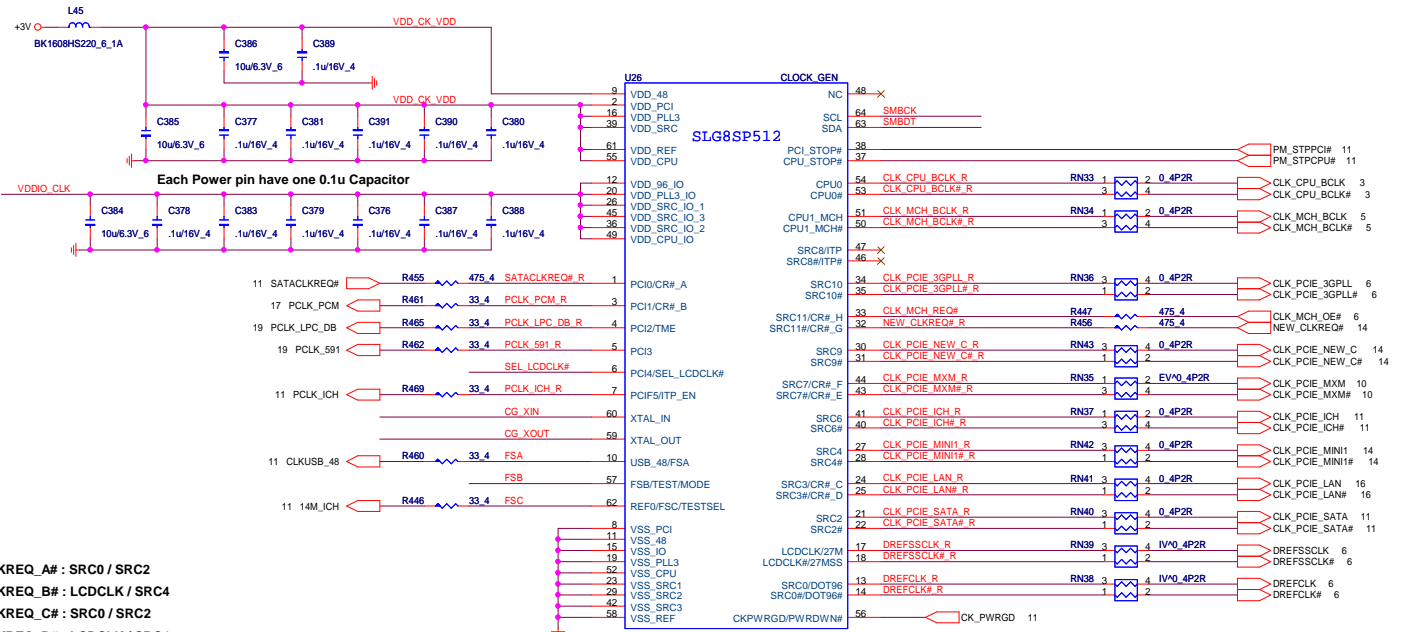

- CLKREQ_A# : SRC0 / SRC2
- CLKREQ_B# : LCDCLK / SRC4
- CLKREQ_C# : SRC0 / SRC2
- CLKREQ_D# : LCDCLK / SRC4
- CLKREQ_E# : SRC6
- CLKREQ_F# : SRC8
- CLKREQ_G# : SRC9
- CLKREQ_H# : SRC10

VDDIO power source for SILEGO

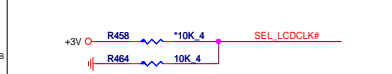
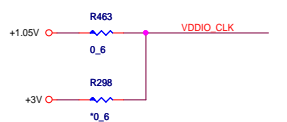

CK505
 0 : Pin 37,38 as SRC5 output
 1 : pin 37,38 as PCI_STOP & CPU_STOP

SILEGO
 0 : Pin 13,14 & 17,18 for Internal VGA
 1 : 27M & 27M_SS & SRC0 for external VGA

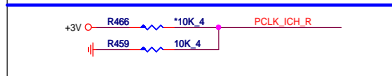

CK505
 0 : Pin 46,47 as SRC output
 1 : Pin 46,47 as CPU output

SILEGO
 0 : Pin 46,47 as SRC output
 1 : Pin 46,47 as CPU output

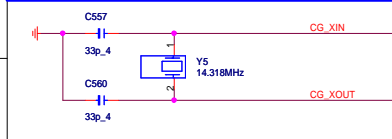

PU for ICS CLK GEN
 0 : CPU & SRC overclock allow
 1 : CPU & SRC overclock not allow

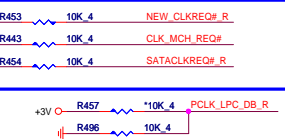

Clock Gen I2C

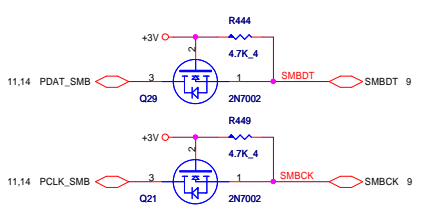

Reserved for EMI

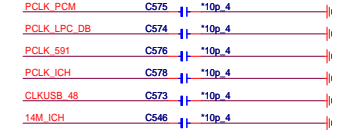

CPU Clock select

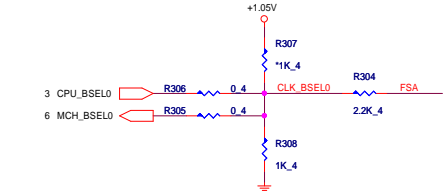
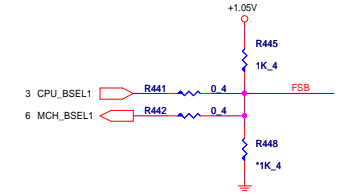
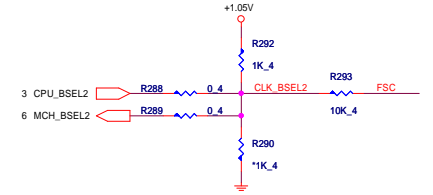

BSEL Frequency Select Table

FSC	FSB	FSA	Frequency
0	0	0	266Mhz
0	0	1	1.33Mhz
0	1	0	200Mhz
0	1	1	166Mhz
1	0	0	333Mhz
1	0	1	100Mhz
1	1	0	400Mhz
1	1	1	Reserved



PROJECT : Z01
Quanta Computer Inc.

Size	Document Number	Rev
CLOCK GENERATOR CK505 W/REGULATOR	CLOCK GENERATOR CK505 W/REGULATOR	1A
Date: Wednesday, October 25, 2006	Sheet 2 of 25	

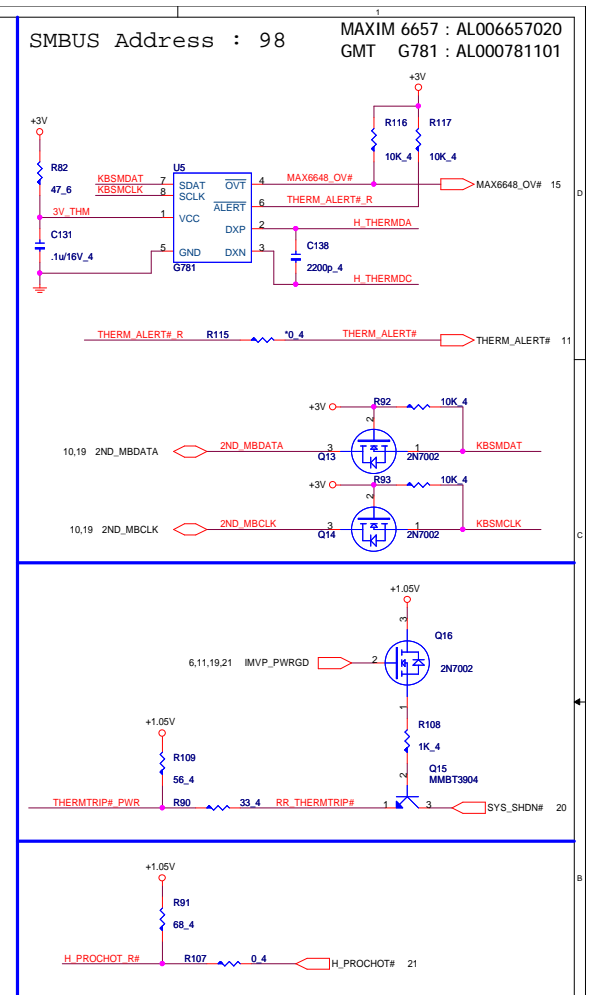
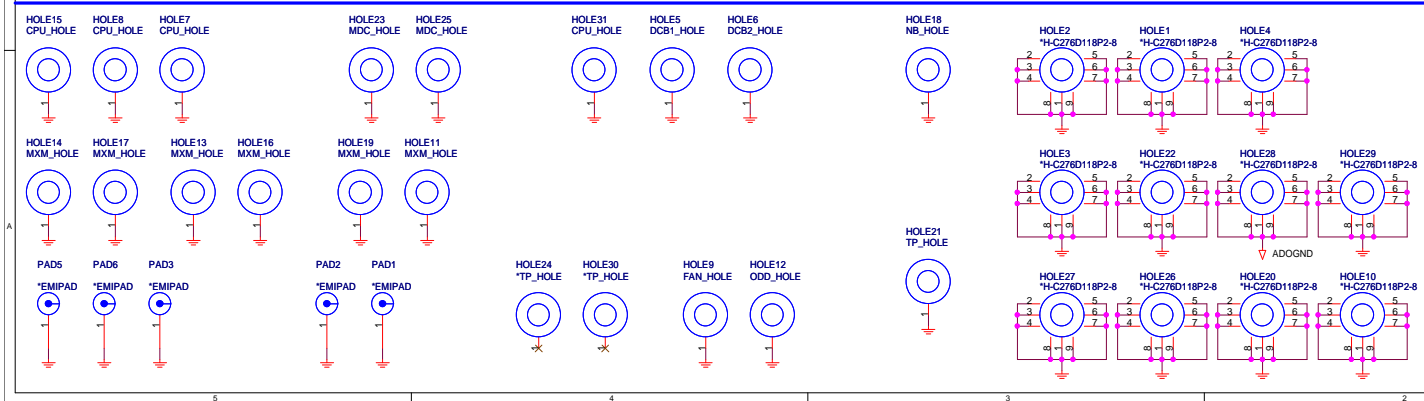
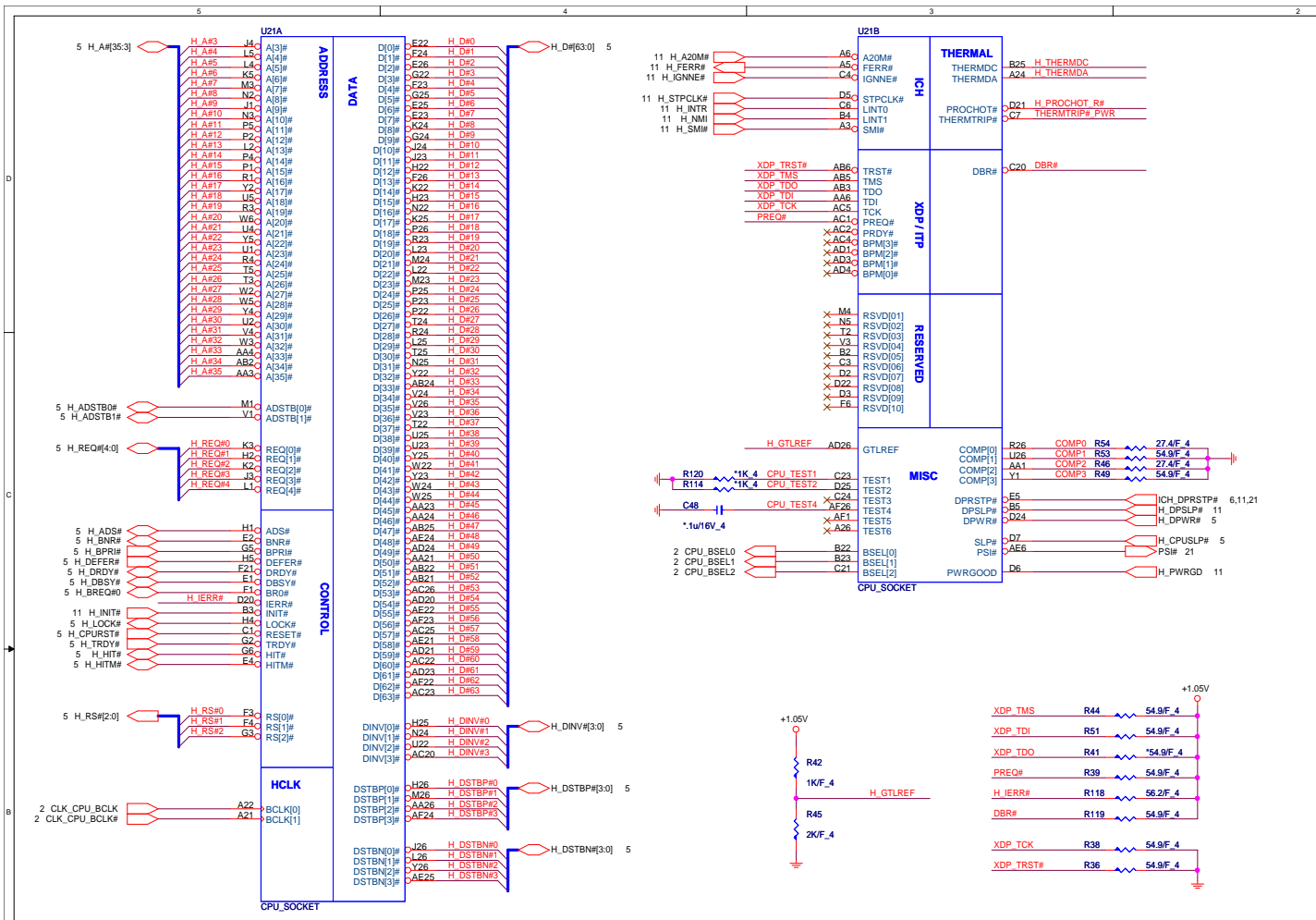

PROJECT : Z01
Quanta Computer Inc.

Size	Document Number	Rev
	CPU(1 of 2)Thermal	1A
Date:	Wednesday, October 25, 2006	Sheet 3 of 25

CPU(Power)

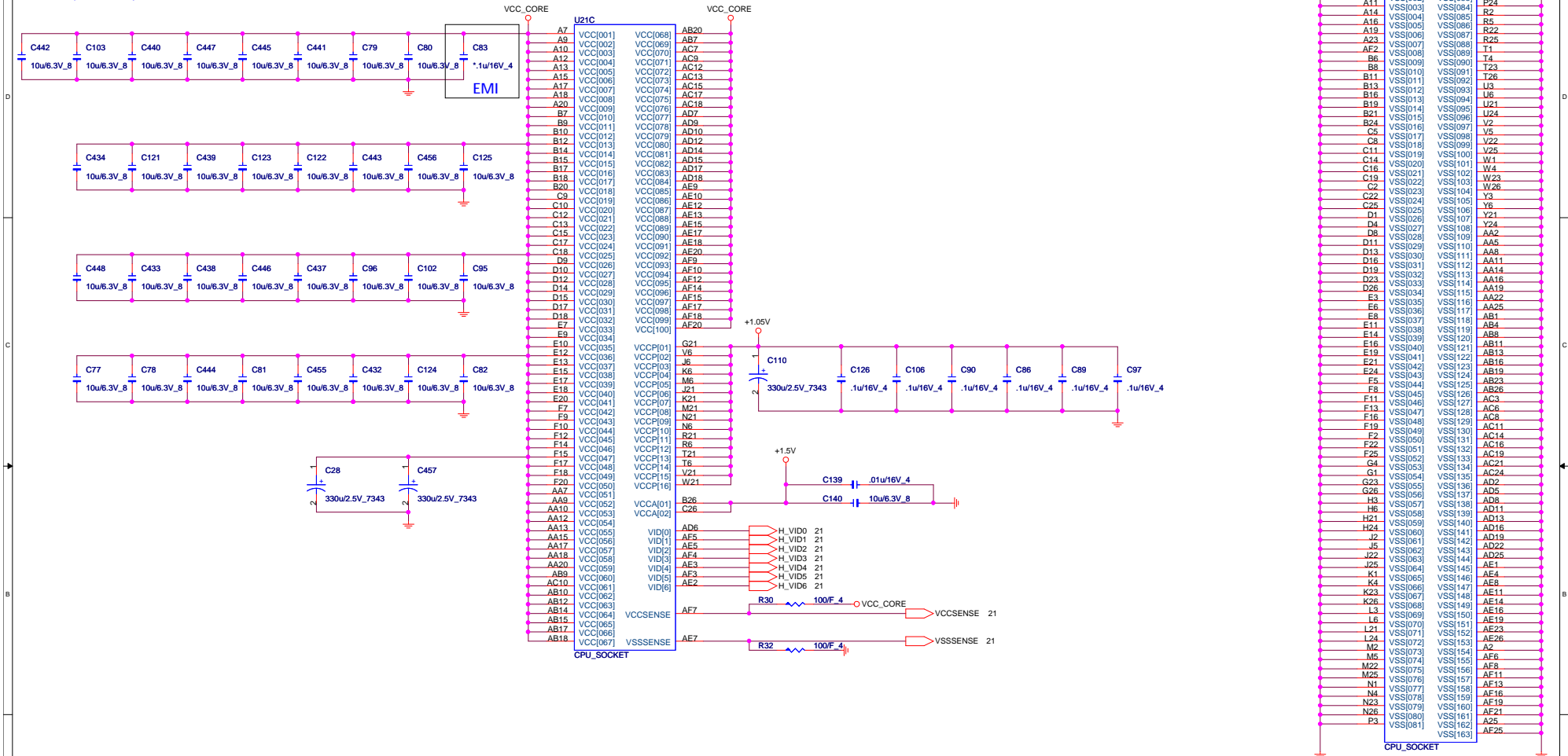

PROJECT : ZO1
Quanta Computer Inc.

Size: Document Number
CPU(2 of 2)Power

Date: Wednesday, October 25, 2006 Sheet 4 of 25 Rev 1A

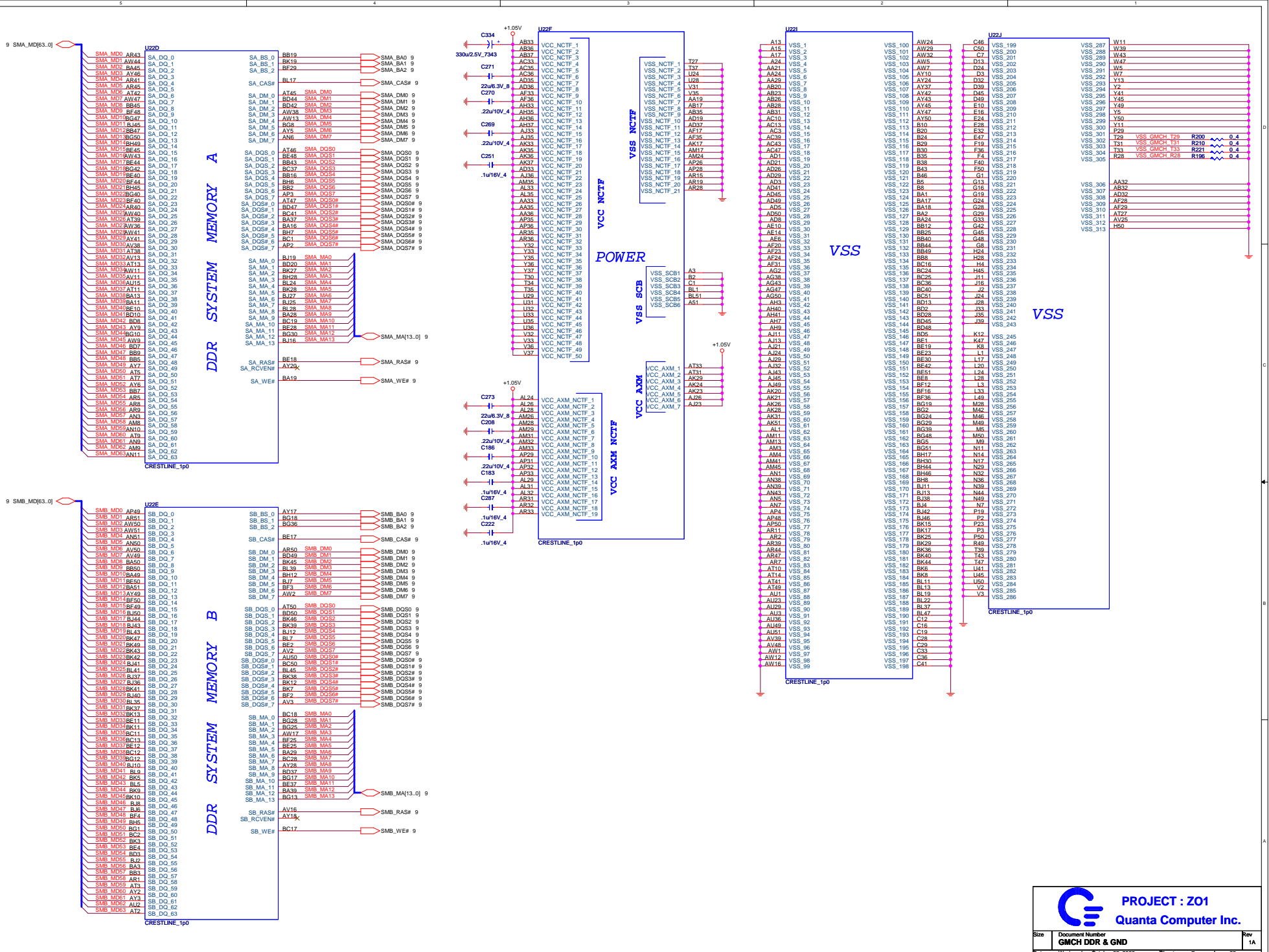

PROJECT : Z01
Quanta Computer Inc.

Size: Document Number: GMCH DDR & GND Rev: 1A
 Date: Wednesday, October 25, 2006 Sheet: 7 of 26

Ball	Enable	Disable	Ball	Enable	Disable
VCCA_CRT	3.3V	GND	VCCA_C_TVO	3.3V	GND
VCCD_CRT	1.5V	GND	VCCD_TVO	3.3V	1.5V
VCCDD_CRT	1.5V	GND	VCCBAG_DAC	3.3V	GND
VCCA_A_TVO	3.3V	GND	VSSBAG_DAC	GND	GND
VCCA_B_TVO	3.3V	GND	VCC_SYNC	3.3V	GND

CRT/TV Disable/Enable guideline

External VGA with EV @part, Internal VGA with IV @ part

LVDS Disable/Enable guideline

External VGA with EV @part, Internal VGA with IV @ part

Signal	If SDVO Disable LVDS Disable	If SDVO enable LVDS Disable	If SDVO enable LVDS enable
VCCD_LVDS	GND	1.8V	1.8V
VCCA_LVDS	GND	GND	1.8V
VCCD_TX_LVDS	GND	GND	1.8V

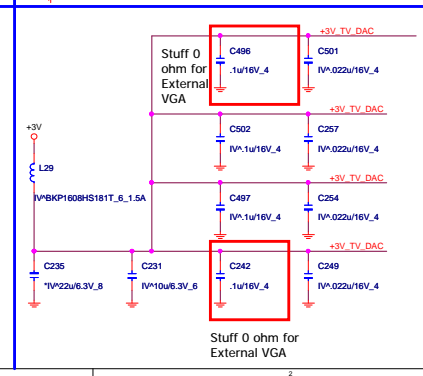
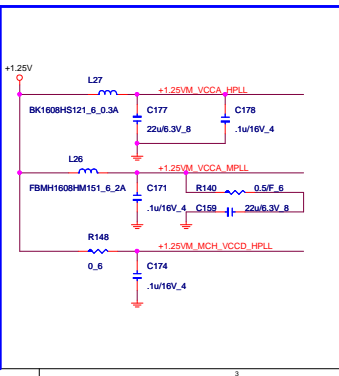
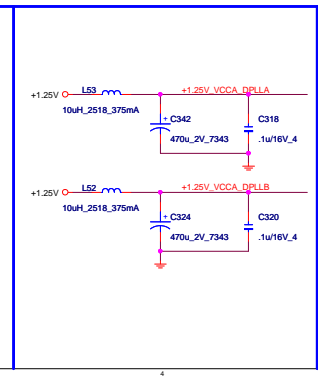
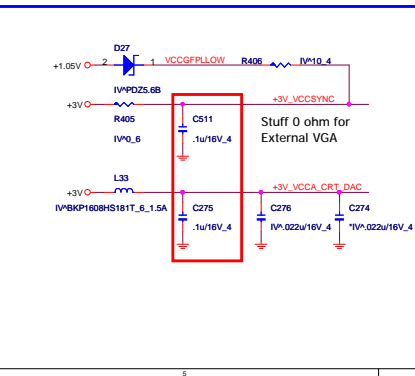
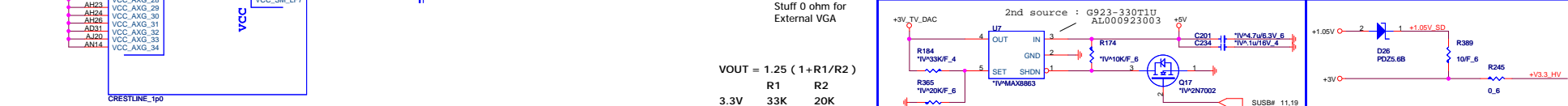
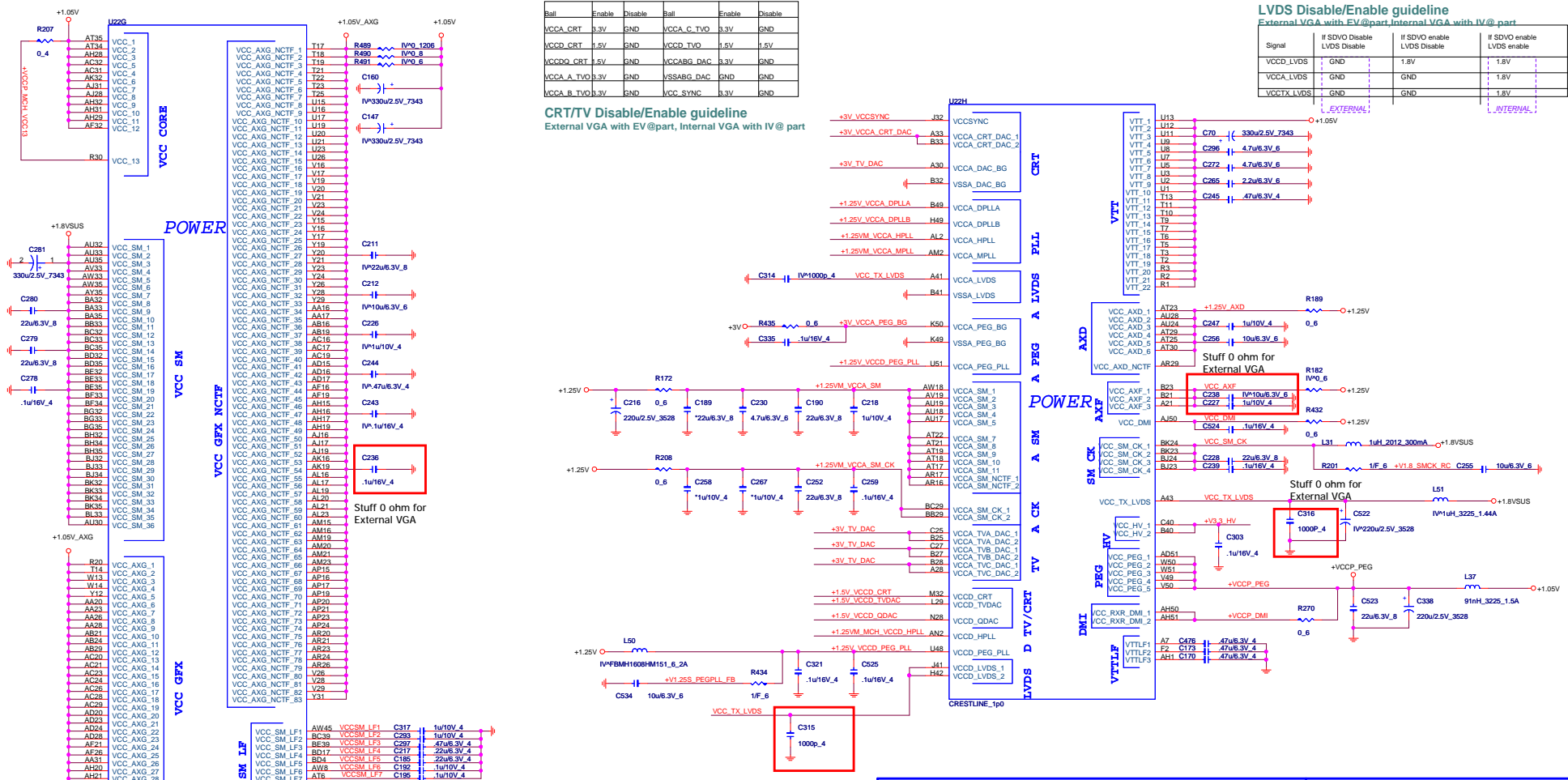

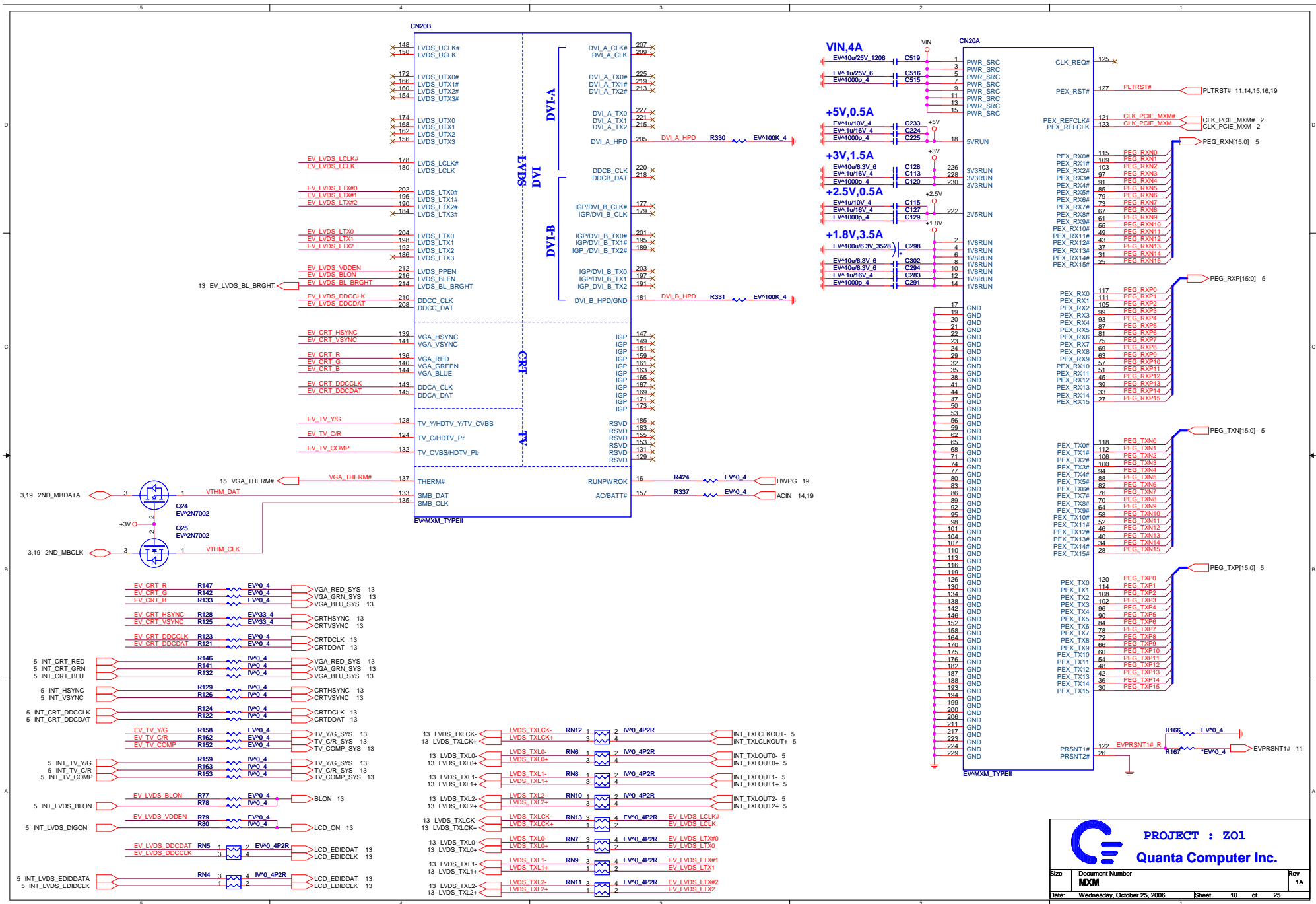

PROJECT : Z01
Quanta Computer Inc.

Size	Document Number	Rev
	MXM	1A
Date:	Wednesday, October 25, 2006	Sheet 10 of 25

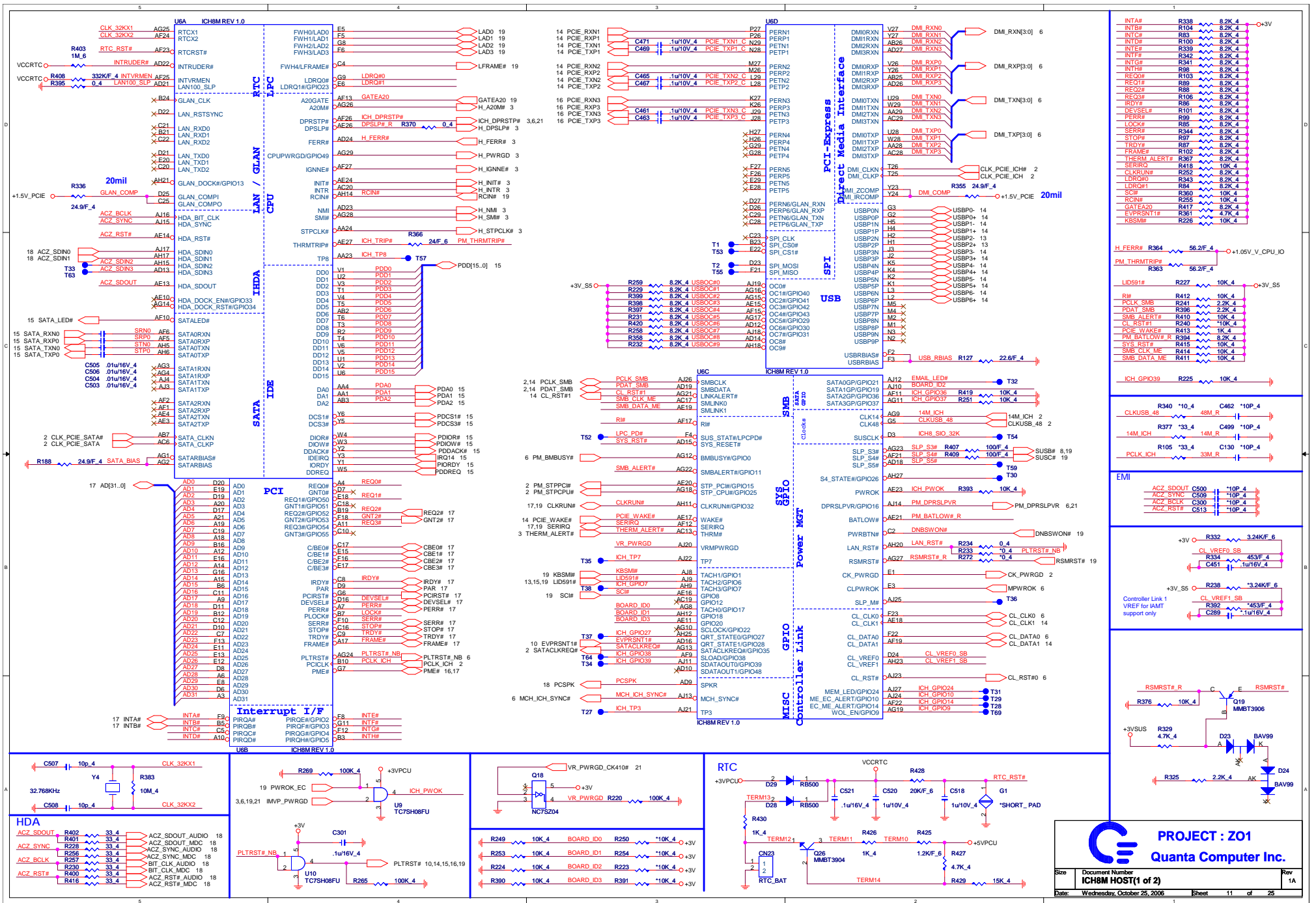

PROJECT: Z01
Quanta Computer Inc.

Size: Document Number: ICH8M HOST(1 of 2)
 Date: Wednesday, October 25, 2006 Sheet: 11 of 25

CRT

UMA mode: C203-208 use 4.7pF (CH-4716TB06)
 MXM mode: C203-208 use 10pF (CH01006JB08)

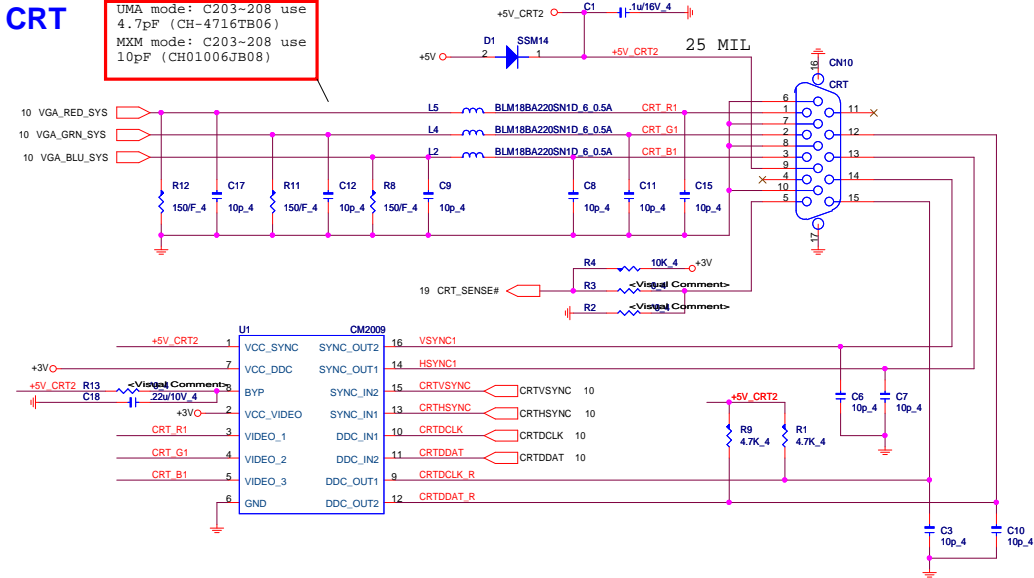

S-VIDEO

UMA mode
 1. C22,24,25,27,31,32 use 6pF CH00606TB04
 2. L8,L9,L10 use CX8HS220009

MXM mode
 1. C22,C27,C32 use 270pF CH12704JB07
 2. C210,C211,C217 use 330pF CH1336K1B02
 3. L8,L9,L10 use CV-1801KN31

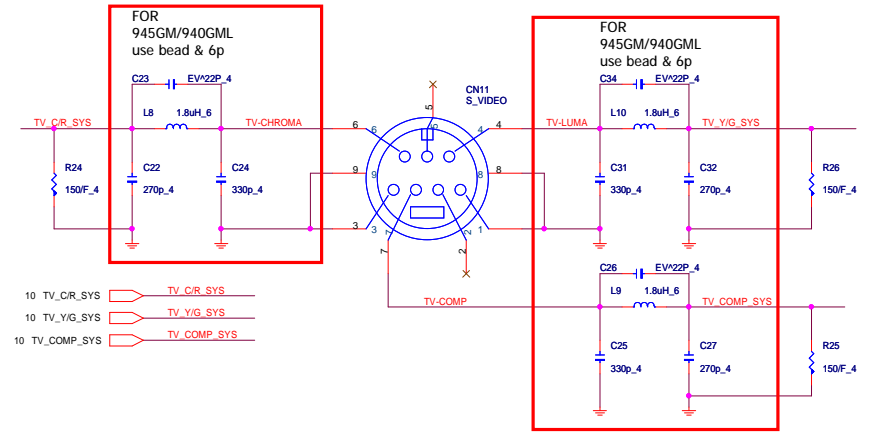

LVDS

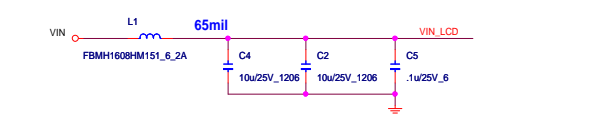
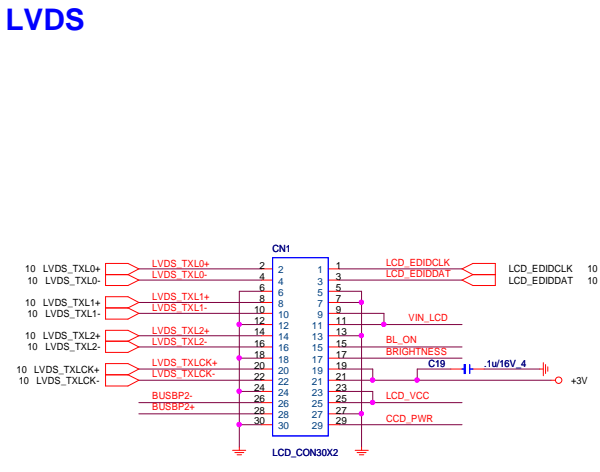

Backlight Control

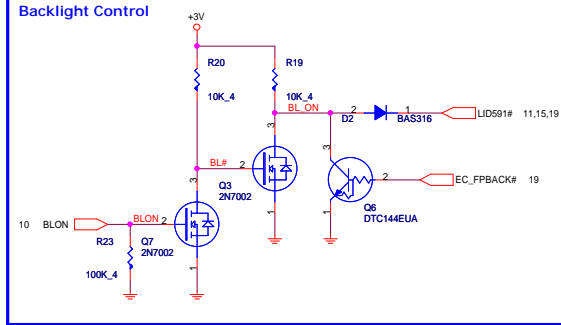

LCD EDID Smbus PU

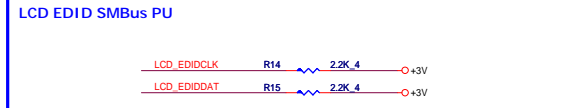

DPST

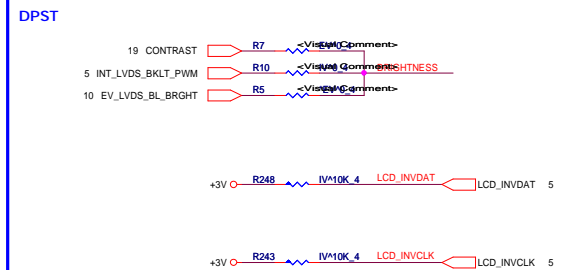

LCD_ON

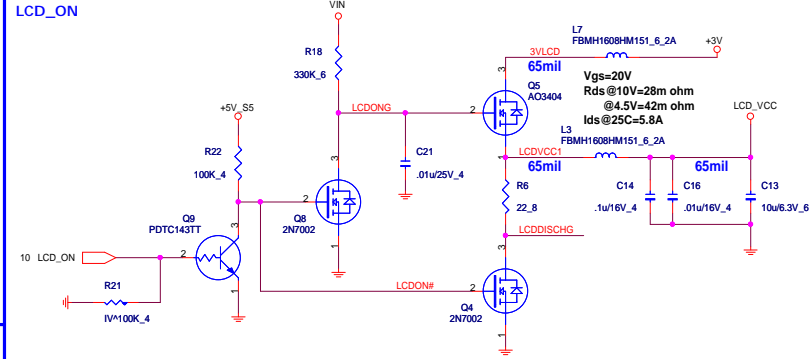

Camera

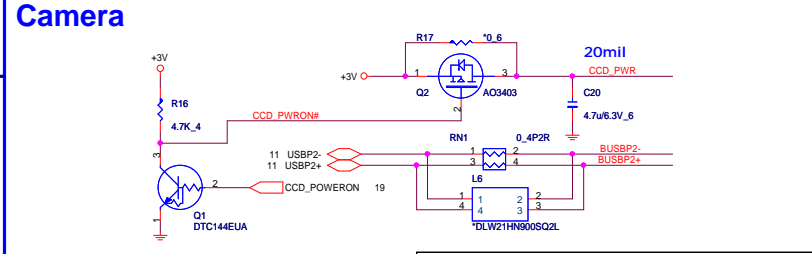

PROJECT : ZO1
Quanta Computer Inc.

Size	Document Number	Rev
	LVDS/CRT/TVOUT/CCD	1A
Date:	Wednesday, October 25, 2006	Sheet 13 of 25

NEW-CARD

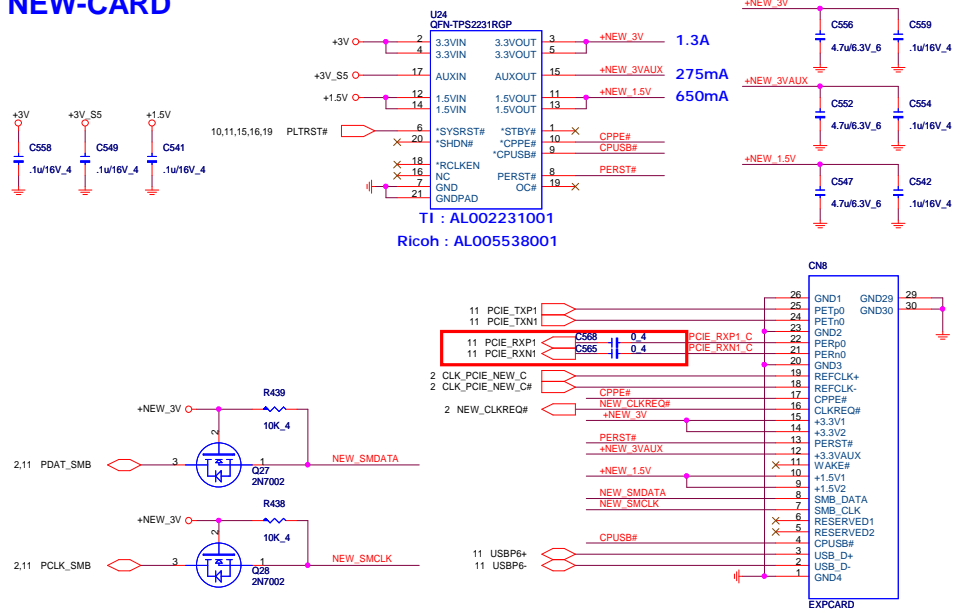

Bluetooth

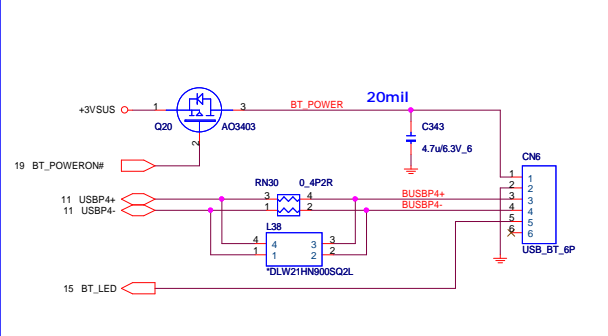

CIR

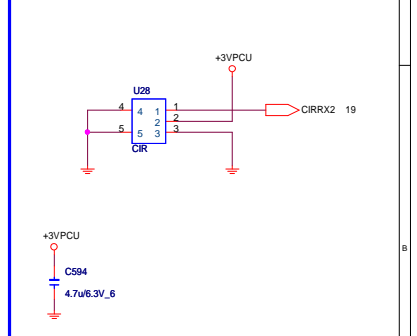

MINI-CARD

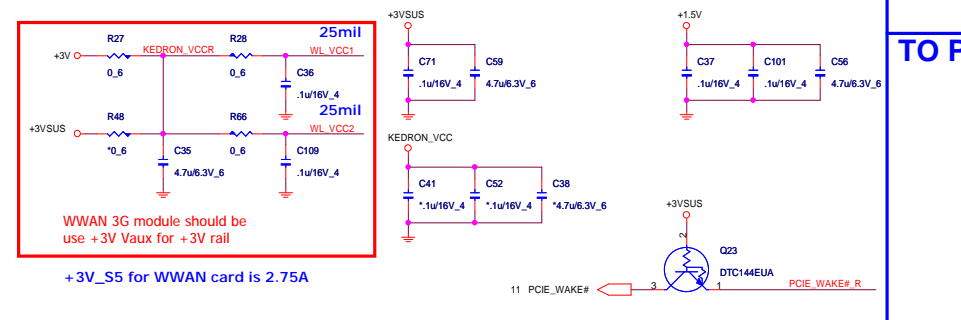
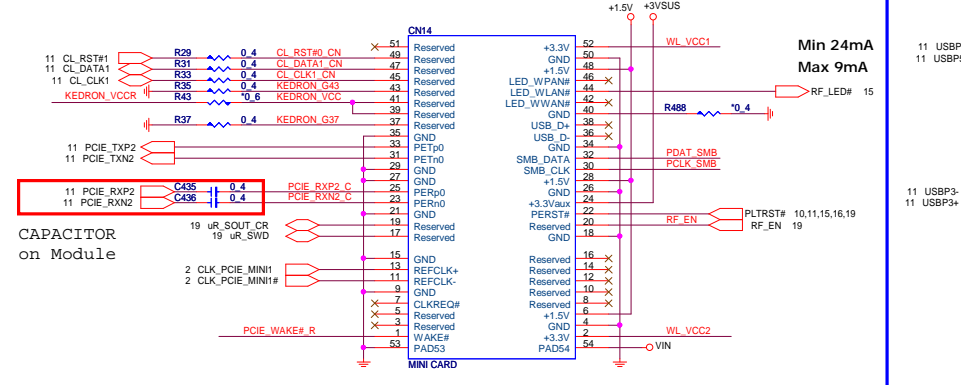

USB

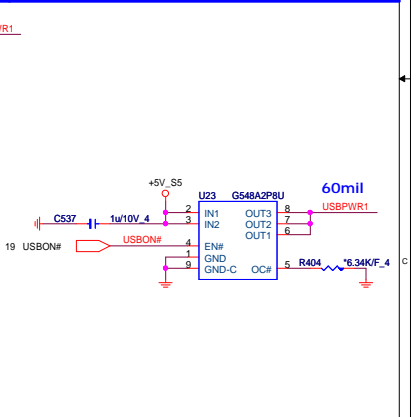
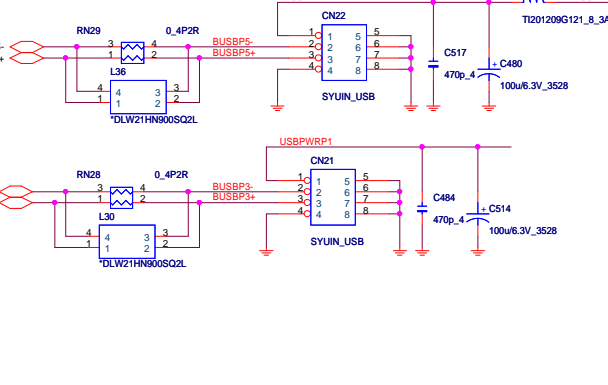

TO POWER/B

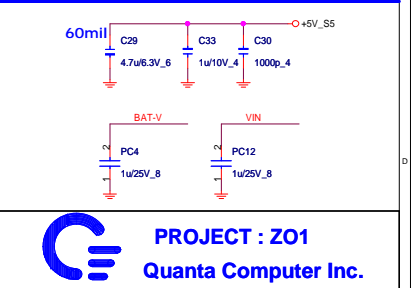
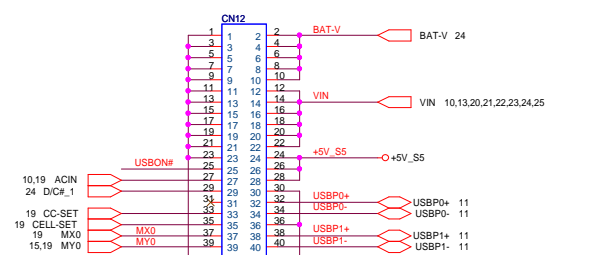

PROJECT : Z01
Quanta Computer Inc.

Size: Document Number: **NEW&MINICARD/USB/BT/CIR/ACIN** Rev: 1A

Date: Wednesday, October 25, 2006 Sheet: 14 of 25

ODD

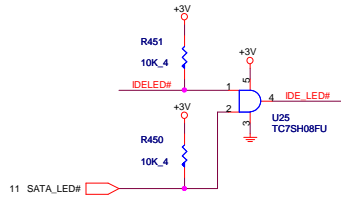
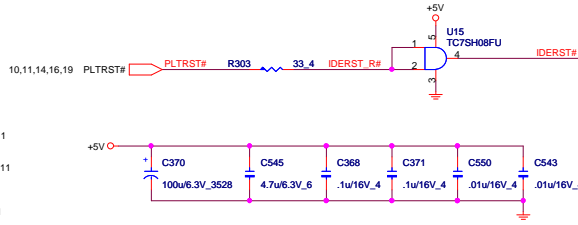
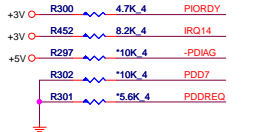
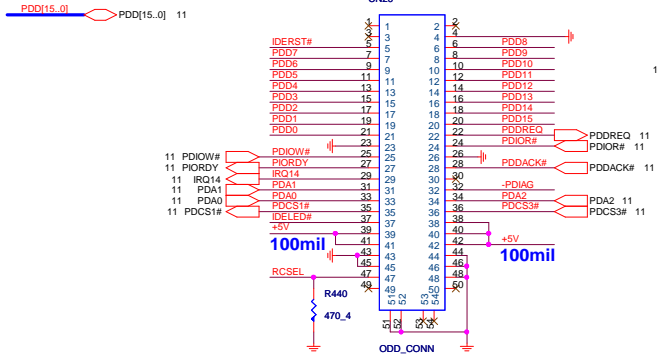

LED

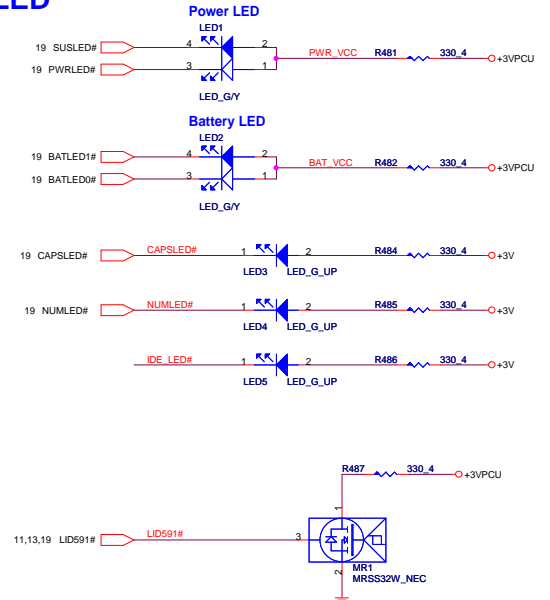

SATA

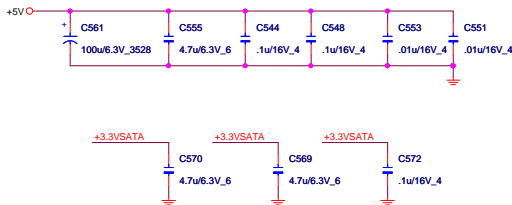
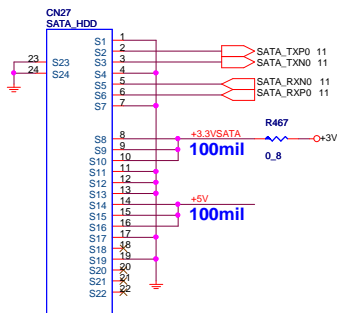

TP CONN

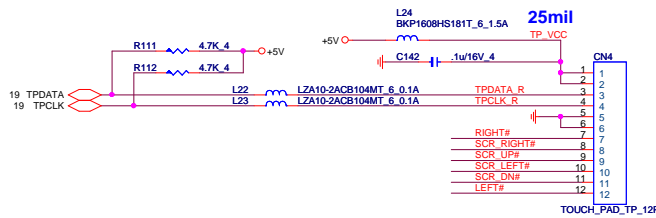

FAN

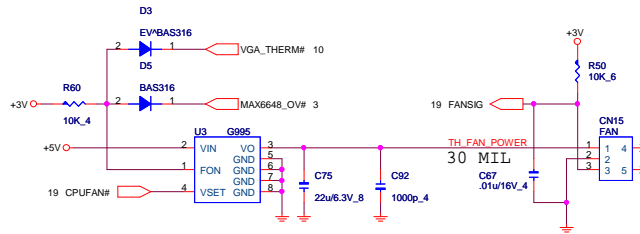

TO SW/B

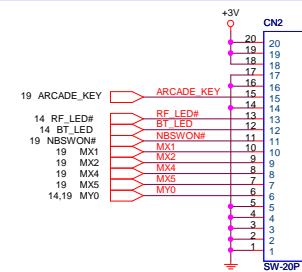

TP SWITCH

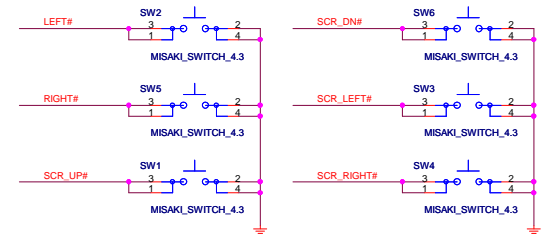

PROJECT : Z01
Quanta Computer Inc.

Size	Document Number	Rev
	HDD/ODD/LED/SW/TP/FAN	1A
Date:	Wednesday, October 25, 2006	Sheet 15 of 25

CODEC(ALC268)

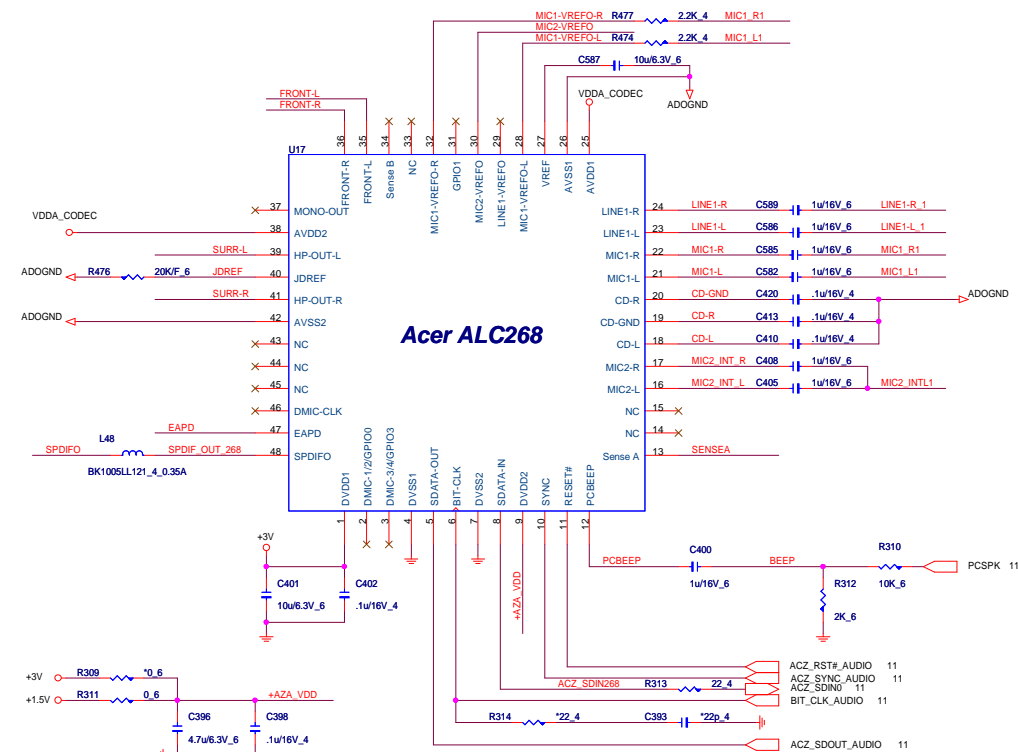

Speaker Amplifier

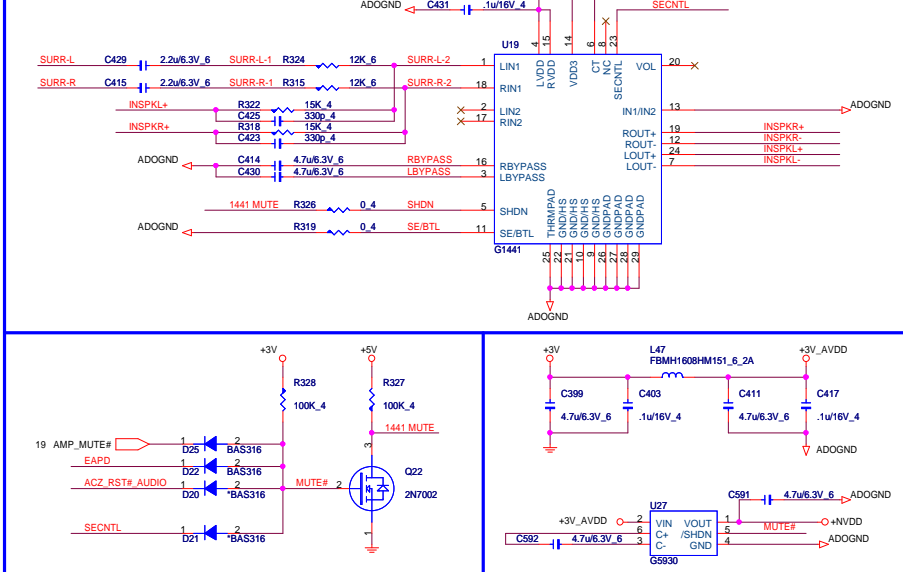

LINE OUT Amplifier

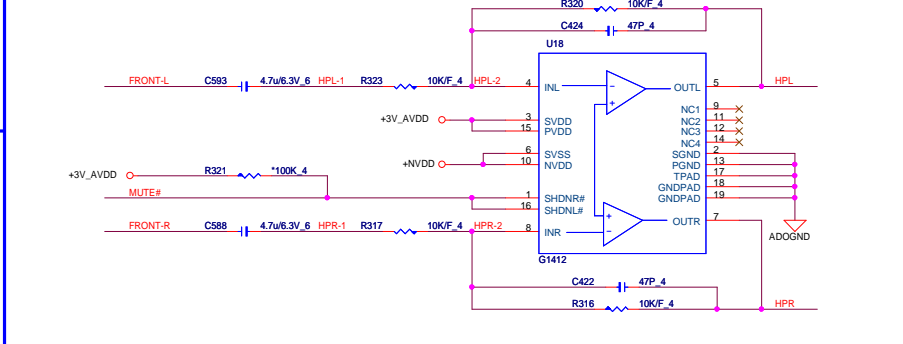

Codec Power

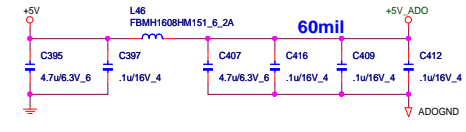
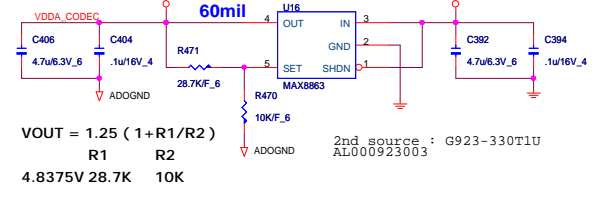

SPEAKER

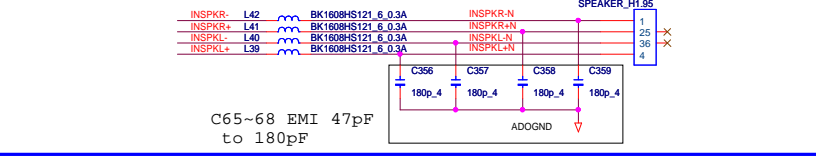

INT MIC array

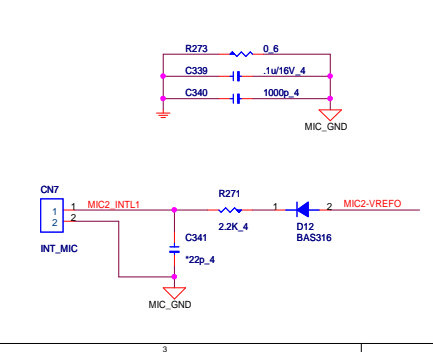

AUDIO/B

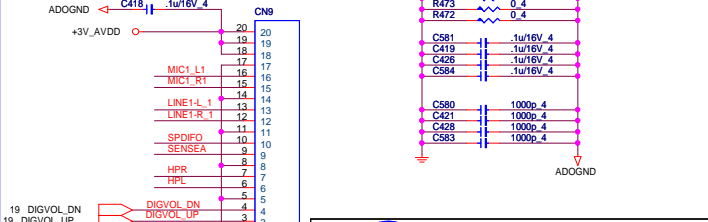

MDC

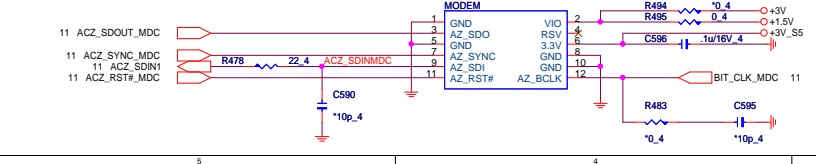



PROJECT : Z01
Quanta Computer Inc.

Size	Document Number	Rev
Date: Wednesday, October 25, 2006	ALC268&MDC	1A
Sheet	18	of 25

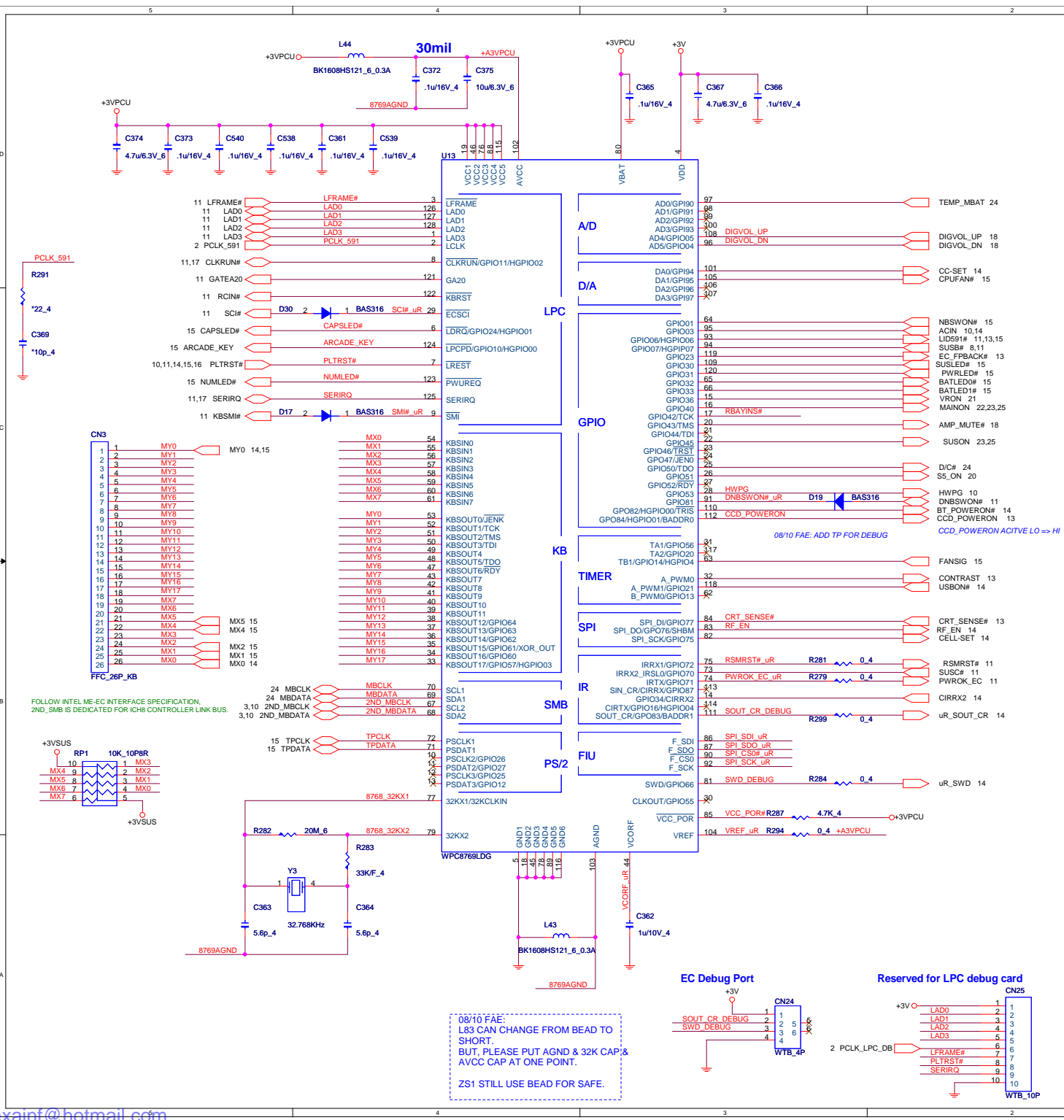

PROJECT : ZO1
Quanta Computer Inc.

Size Document Number Rev
PC8769L & FLASH 1A

Date: Wednesday, October 25, 2006 Sheet 19 of 25

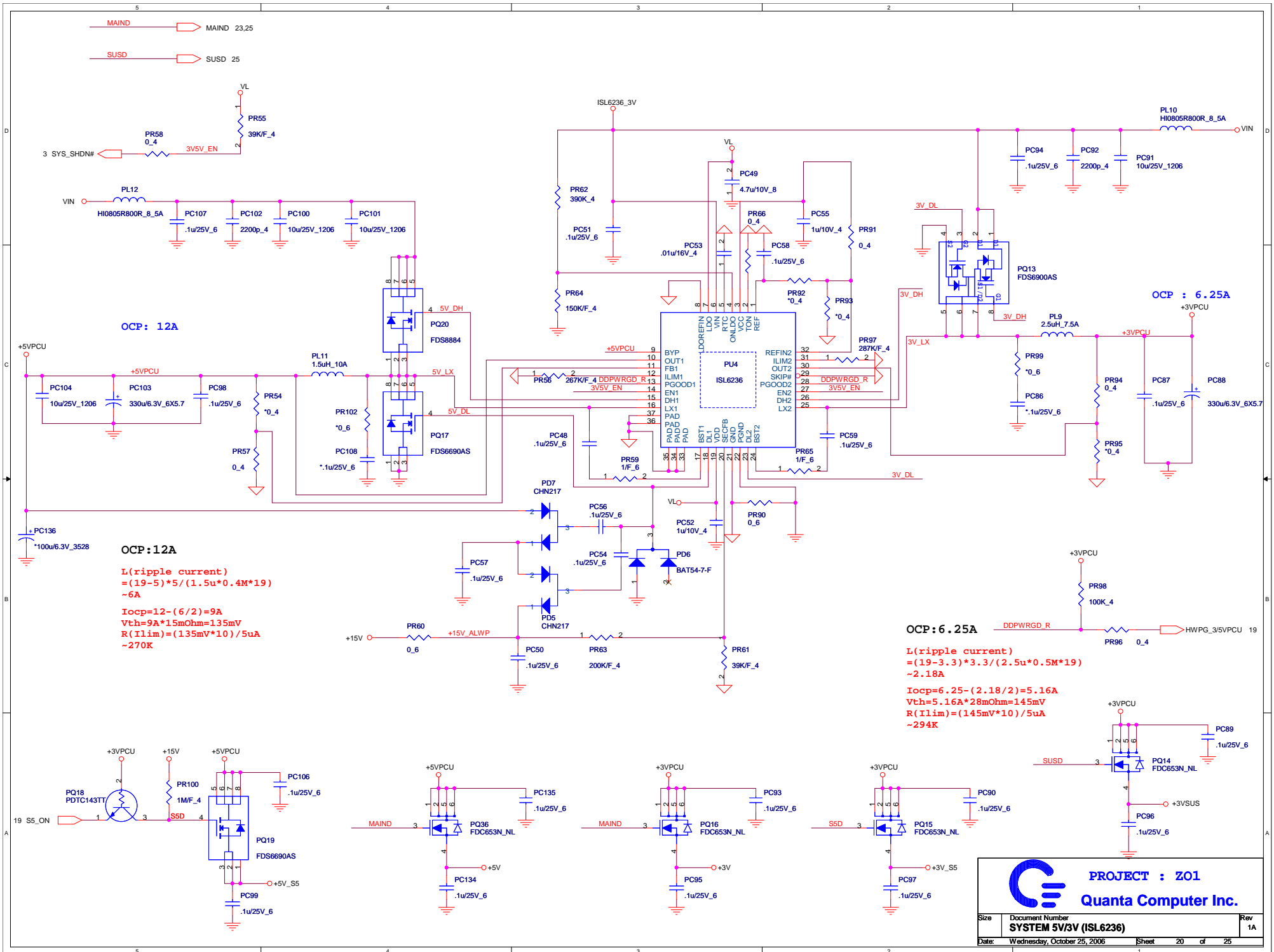

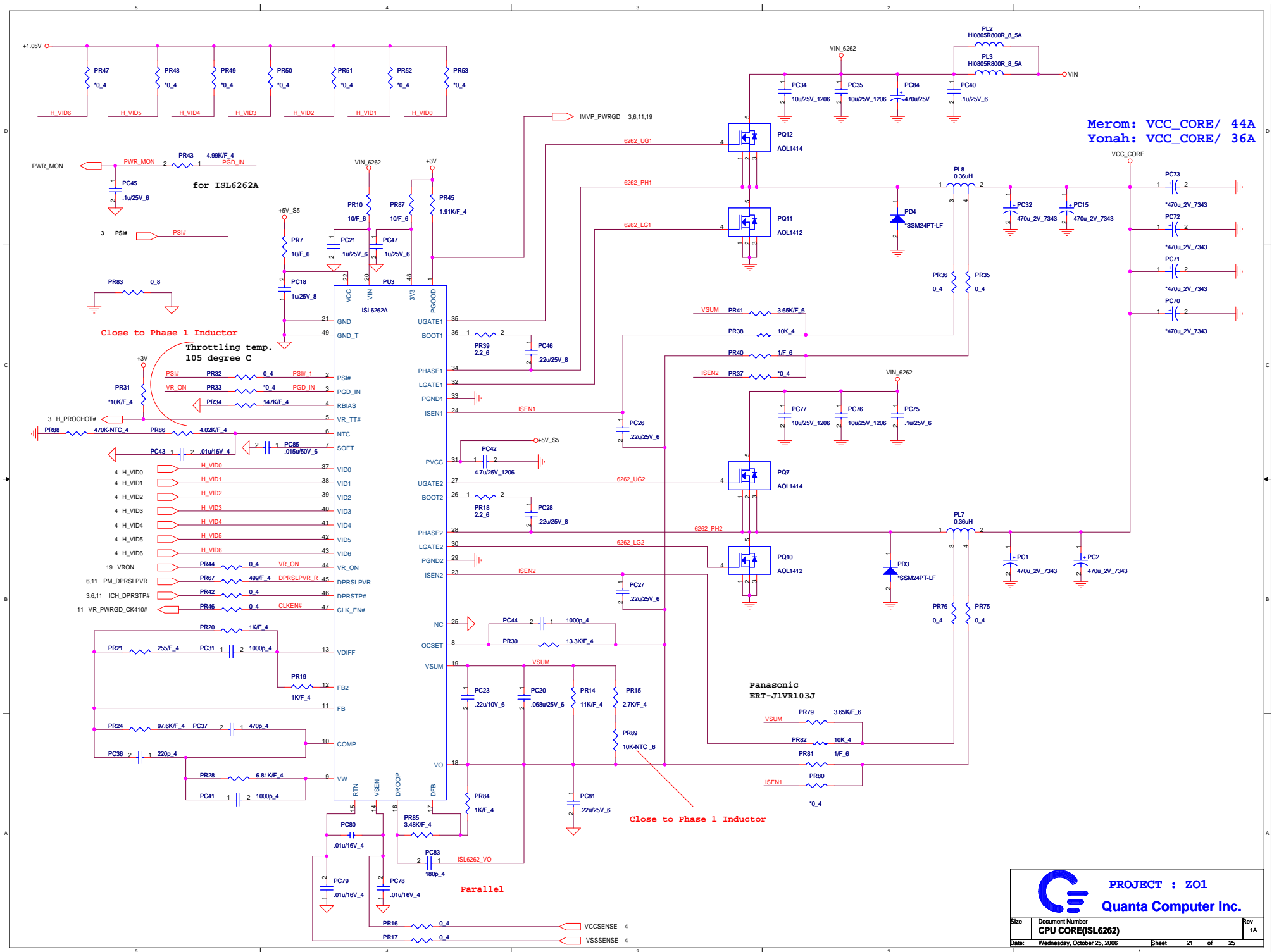

PROJECT : Z01
Quanta Computer Inc.

Size	Document Number	Rev
	CPU CORE(ISL6262)	1A
Date:	Wednesday, October 25, 2006	Sheet 21 of 25

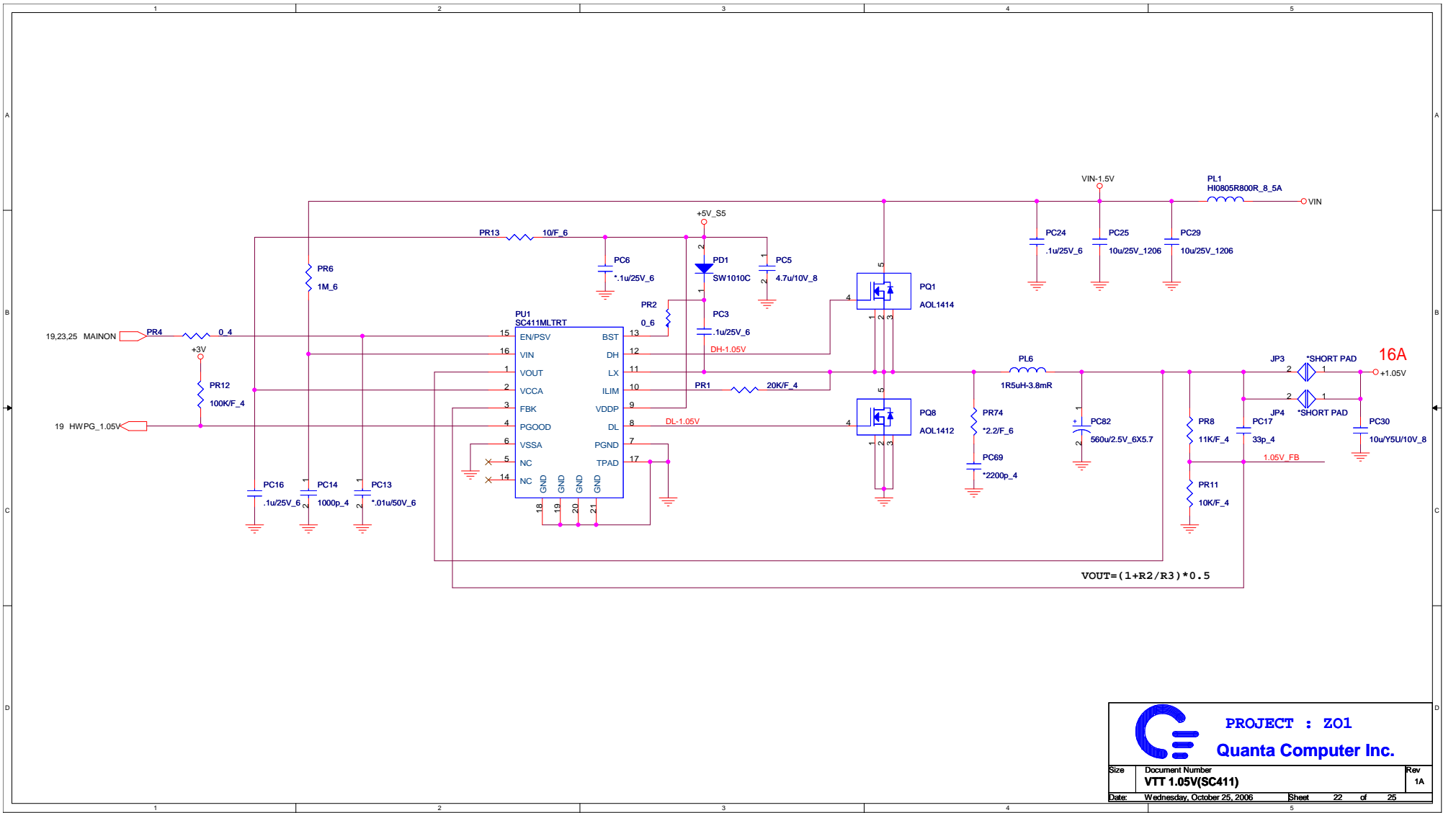

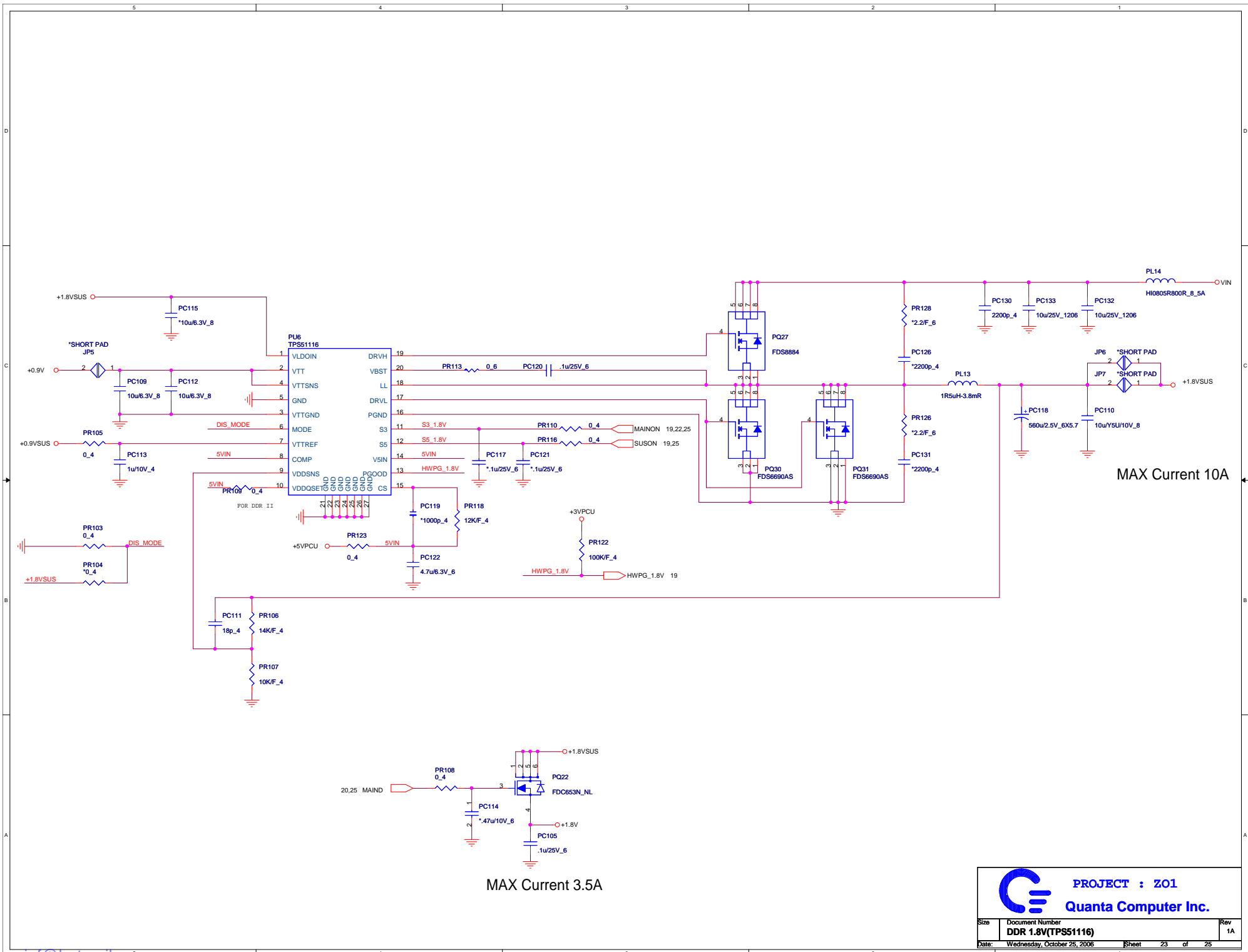

PROJECT : Z01
Quanta Computer Inc.

Size	Document Number	Rev
	VTT 1.05V(SC411)	1A
Date:	Wednesday, October 25, 2006	Sheet 22 of 25



MAX Current 10A

MAX Current 3.5A

 PROJECT : ZO1 Quanta Computer Inc.		Size	Document Number	Rev
			DDR 1.8V(TPS51116)	1A
Date:	Wednesday, October 25, 2006	Sheet	23	of 25

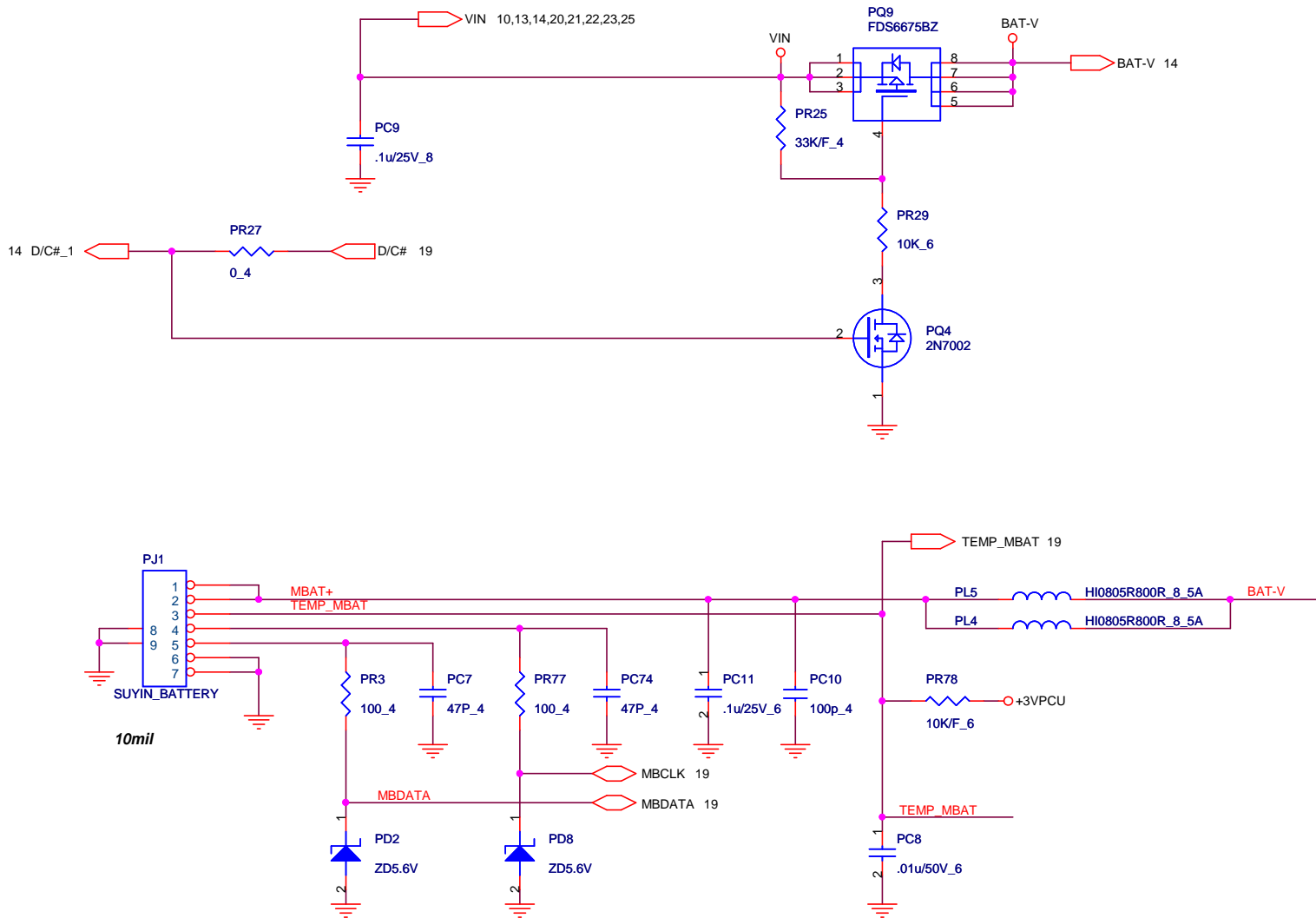

PROJECT : Z01
Quanta Computer Inc.

Size	Document Number	Rev
	CHARGER (ISL6251A)	1A
Date:	Wednesday, October 25, 2006	Sheet 24 of 25

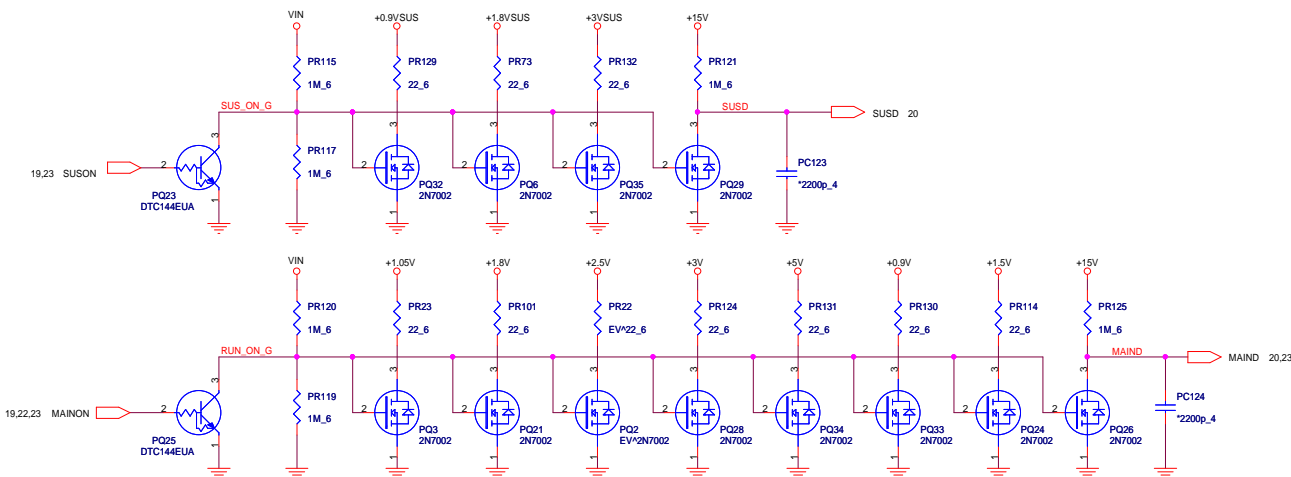
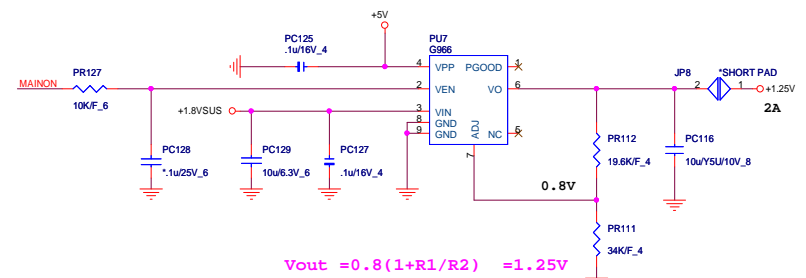
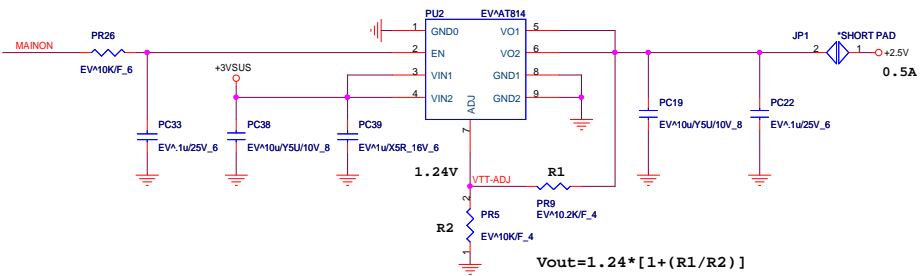
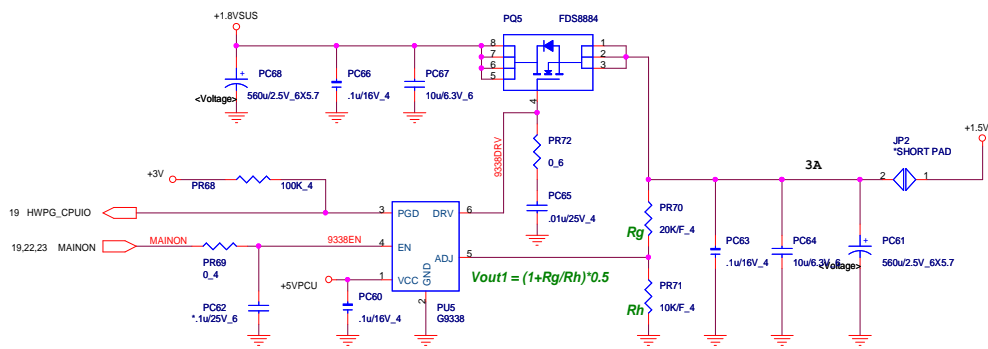

PROJECT : ZO1
Quanta Computer Inc.

Size	Document Number	Rev
	Discharge (1.5V/2.5V/1.25V)	1A
Date:	Wednesday, October 25, 2006	Sheet 25 of 25